

CLASS 150 FLANGES

ASME B16.5

ASME B16.5 FORGED FLANGES

Nominal Pipe Size	Outside Diam.	O.D. of Raised Face	Diam. at Base of Hub	Thickness	BORE			LENGTH THRU HUB			Diam. of Hub at Bevel	Radius of Fillet	Thread Length
					Welding Neck Socket Welding	Slip-on Socket Welding	Lap Joint	Welding Neck	Slip-on Threaded Socket Welding	Lap Joint			
					B1	B2	B3	T1	T2	T3			
1/2	88.9	35.1	30.2	11.2	15.7	22.4	22.9	47.8	15.7	15.7	21.3	3.0	15.7
3/4	98.6	42.9	38.1	12.7	20.8	27.7	28.2	52.3	15.7	15.7	26.7	3.0	15.7
1	108.0	50.8	49.3	14.2	26.7	34.5	35.1	55.6	17.5	17.5	33.5	3.0	17.5
1 1/4	117.3	63.5	58.7	15.7	35.1	43.2	43.7	57.2	20.6	20.6	42.2	5.0	20.6
1 1/2	127.0	73.2	65.0	17.5	40.9	49.5	50.0	62.0	22.4	22.4	48.3	6.0	22.4
2	152.4	91.9	77.7	19.1	52.6	62.0	62.5	63.5	25.4	25.4	60.5	8.0	25.4
2 1/2	177.8	104.6	90.4	22.4	62.7	74.7	75.4	69.9	28.4	28.4	73.2	8.0	28.4
3	190.5	127.0	108.0	23.9	78.0	90.7	91.4	69.9	30.2	30.2	88.9	10.0	30.2
3 1/2	215.9	139.7	122.2	23.9	90.2	103.4	104.1	71.4	31.8	31.8	101.6	10.0	31.8
4	228.6	157.2	134.9	23.9	102.4	116.1	116.8	76.2	33.3	33.3	114.3	11.0	33.3
5	254.0	185.7	163.6	23.9	128.3	143.8	144.5	88.9	36.6	36.6	141.2	11.0	36.6
6	279.4	215.9	192.0	25.4	154.2	170.7	171.5	88.9	39.6	39.6	168.4	13.0	39.6
8	342.9	269.7	246.1	28.4	202.7	221.5	222.3	101.6	44.5	44.5	219.2	13.0	44.5
10	406.4	323.9	304.8	30.2	254.5	276.4	277.4	101.6	49.3	49.3	273.1	13.0	49.3
12	482.6	381.0	365.3	31.8	304.8	327.2	328.2	114.3	55.6	55.6	323.9	13.0	55.6
14	533.4	412.8	400.1	35.1	336.6	359.2	360.2	127.0	57.2	79.2	355.6	13.0	57.2
16	596.9	469.9	457.2	36.6	387.4	410.5	411.2	127.0	63.5	87.4	406.4	13.0	63.5
18	635.0	533.4	505.5	39.6	438.2	461.8	462.3	139.7	68.3	97.0	457.2	13.0	68.3
20	698.5	584.2	558.8	42.9	489.0	513.1	514.4	144.5	73.2	103.1	508.0	13.0	73.2
24	815	692.2	663.4	47.8	590.6	616.0	616.0	152.4	82.6	111.3	609.6	13.0	82.6

Notes

- (1) For the 'Bore' (B1) other than Standard Wall Thickness, refer to page 50, 51.
- (2) Class 150 flanges except Lap Joint will be furnished with 0.06" (1.6mm) raised face, which is included in 'Thickness' (t) and 'Length through Hub' (T1), (T2).
- (3) For Slip-on, Threaded, Socket Welding and Lap Joint Flanges, the hubs can be shaped either vertical from base to top or tapered within the limits of 7 degrees.

CLASS 150 FLANGES

ASME B16.5

ASME B16.5 FORGED FLANGES

Nominal Pipe Size	Depth of Socket	DRILLING			BOLTING			APPROXIMATE WEIGHT										
		Bolt Circle Diam.	Number of Holes	Diam of Holes	Diam of Bolt (inch)	Machine Bolt Length		Stud Bolt Length	Welding Neck		Slip-on and Threaded		Lap Joint		Blind		Socket Welding	
						Raised Face	Ring Joint		Kg	lb	Kg	lb	Kg	lb	Kg	lb	Kg	lb
1/2	9.7	60.5	4	15.8	1/2	50	55	-	0.52	1.10	0.47	1.00	0.51	1.00	0.47	1.00	0.47	1.00
3/4	11.2	69.9	4	15.8	1/2	50	65	-	0.92	1.60	0.75	1.30	0.70	1.40	0.70	1.40	0.76	1.30
1	12.7	79.2	4	15.8	1/2	55	65	75	1.10	2.40	0.86	1.90	0.93	1.80	0.95	2.10	0.90	1.90
1 1/4	14.2	88.9	4	15.8	1/2	55	70	85	1.40	3.10	1.40	2.40	1.40	2.00	1.40	2.70	1.43	2.40
1 1/2	15.7	98.6	4	15.8	1/2	65	70	85	1.81	4.00	1.41	3.10	1.51	3.30	1.62	36.0	15.0	3.20
2	17.5	120.7	4	19.1	5/8	70	85	95	2.80	5.70	2.26	5.00	2.38	5.20	2.64	5.80	2.33	5.00
2 1/2	19.1	139.7	4	19.1	5/8	75	90	100	4.28	9.40	3.60	7.60	3.60	7.90	4.10	9.00	3.70	7.80
3	20.6	152.4	4	19.1	5/8	75	90	100	5.18	11.40	4.10	8.50	4.04	8.90	5.00	10.80	4.20	8.90
3 1/2	22.4	177.8	8	19.1	5/8	75	90	100	5.50	12.00	5.20	11.00	4.99	11.00	6.40	13.00	5.00	11.00
4	23.9	190.5	8	19.1	5/8	75	90	100	7.32	16.10	5.75	12.70	5.96	13.00	7.50	16.30	5.99	13.20
5	23.9	215.9	8	22.2	3/4	85	95	110	8.91	19.60	6.51	13.70	6.44	14.00	9.00	19.30	6.96	14.70
6	26.9	241.3	8	22.2	3/4	85	100	115	11.26	24.80	7.81	16.30	7.70	16.70	12.00	24.90	8.41	17.60
8	31.8	298.5	8	22.2	3/4	90	110	120	18.00	39.00	13.00	27.30	12.66	27.90	21.00	43.90	13.93	29.30
10	33.3	362.0	12	25.4	7/8	100	115	125	25.00	54.70	18.50	37.70	17.00	37.00	30.00	64.80	19.50	43.00
12	39.6	431.8	12	25.4	7/8	100	120	135	38.98	85.90	28.00	61.00	28.30	62.40	45.00	96.30	29.03	64.00
14	41.4	476.3	12	28.5	1	115	135	145	51.71	114.00	36.00	77.60	41.50	91.50	64.00	140.00	38.56	85.00
16	44.5	539.8	16	28.5	1	115	135	145	64.41	142.00	46.00	93.00	52.98	116.80	79.00	170.00	47.37	98.00
18	49.3	577.9	16	31.8	1 1/8	125	145	160	74.84	165.00	54.00	109.60	68.00	130.00	97.00	209.00	58.72	120.00
20	54.1	635.0	20	31.8	1 1/8	140	160	170	89.36	197.00	73.00	140.00	85.00	159.00	125.00	272.00	77.81	155.00
24	63.5	749.3	20	35.1	1 1/8	150	170	185	119.66	263.80	96.00	199.50	120.00	218.30	190.00	415.00	100.75	210.00

- (4) Blind Flanges may be made with the same hub as that used for Slip-on Flanges or without hub.
- (5) The gasket surface and backside (bearing surface for bolting) are made parallel within 1 degree. To accomplish parallelism, spot facing is carried out according to MSS AP-9, without reducing thickness (t).
- (6) Depth of Socket (Y) is covered by ANSI B16.5 only in sizes through 3 inch, over 3 inch is at the manufacturer's option.

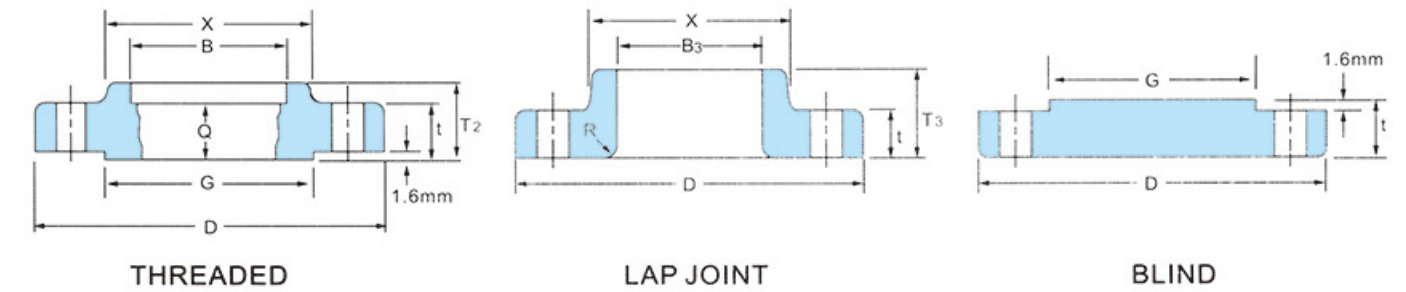
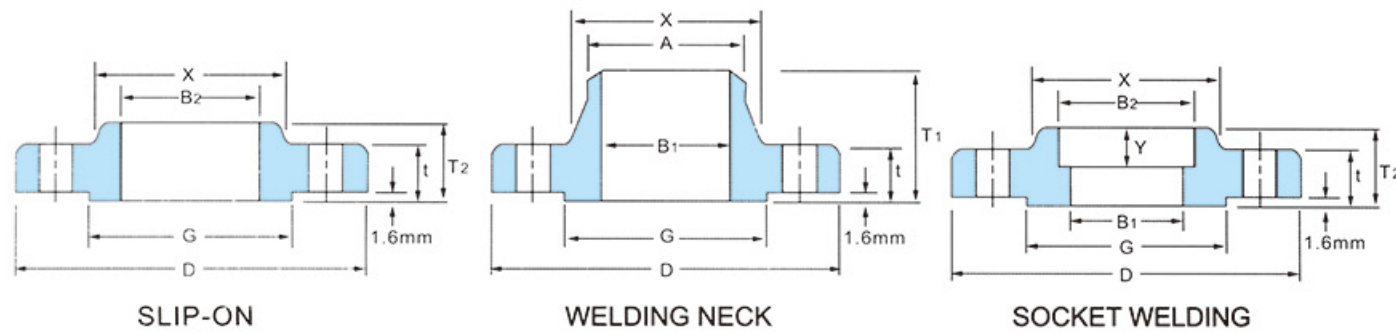

CLASS 300 FLANGES

ASME B16.5

ASME B16.5 FORGED FLANGES

Nominal Pipe Size	Outside Diam.	Diam. at Base of Hub	O.D. of Raised Face	Thickness	BORE				LENGTH THRU HUB			Diam. of Hub at Bevel	Radius of Fillet	Thread Length
					Welding Neck Socket Welding	Slip-on Socket Welding	Lap Joint	Counter Bore Min. Threaded Min.	Welding Neck	Slip-on Threaded Socket Welding	Lap Joint			
D	x	G	t	B1	B2	B3	B	T1	T2	T3	A	R	Q	
1/2	95.3	38.1	35.1	14.2	15.7	22.4	22.9	23.6	52.3	22.4	22.4	21.3	3.0	16.0
3/4	117.3	48.0	42.9	15.9	20.8	27.7	28.2	29.0	57.2	25.4	25.4	26.7	3.0	16.0
1	124.0	54.0	50.8	17.5	26.7	34.5	35.1	35.8	62.0	26.9	26.9	33.5	3.0	18.0
1 1/4	133.4	64.0	63.5	19.1	35.1	43.2	43.7	44.5	65.0	26.9	26.9	42.2	5.0	21.0
1 1/2	155.4	70.0	73.2	20.6	40.9	49.5	50.0	50.5	68.3	30.2	30.2	48.3	6.0	23.0
2	165.1	84.1	91.9	22.4	52.6	62.0	62.5	63.5	69.9	33.3	33.3	60.5	8.0	29.0
2 1/2	190.5	100.1	104.6	25.4	62.7	74.7	75.4	76.2	76.2	38.1	38.1	73.2	8.0	32.0
3	209.6	117.3	127.0	28.6	78.0	90.7	91.4	92.2	79.2	42.9	43.9	88.9	10.0	32.0
3 1/2	228.6	133.4	139.7	30.2	90.2	103.4	104.1	104.9	81.0	44.5	44.5	101.6	10.0	37.0
4	254.0	146.1	157.2	31.8	102.4	116.1	116.8	117.6	85.9	47.8	47.8	114.3	11.0	37.0
5	279.4	177.8	185.7	35.1	128.3	143.8	144.5	144.5	98.6	50.8	50.8	141.2	11.0	43.0
6	317.5	206.2	215.9	36.6	154.2	170.7	171.5	171.5	98.6	52.3	52.3	168.4	13.0	47.0
8	381.0	260.4	269.7	41.1	202.7	221.5	222.3	222.3	111.3	62.0	62.0	219.2	13.0	51.0
10	444.5	321.0	323.9	47.8	254.5	276.4	277.4	276.4	117.3	66.5	95.3	273.1	13.0	56.0
12	520.7	374.7	381.0	50.8	304.8	327.2	328.2	328.7	130.0	73.2	101.6	323.9	13.0	61.0
14	584.2	425.5	412.8	53.8	336.6	359.2	360.2	360.4	142.7	76.2	111.3	355.6	13.0	64.0
16	647.7	483.0	469.9	57.2	387.4	410.5	411.2	411.2	146.1	82.6	120.7	406.4	13.0	69.0
18	711.2	533.4	533.4	60.5	438.2	461.8	462.3	462.0	158.8	88.9	130.0	457.2	13.0	70.0
20	774.7	587.2	584.2	63.5	489.0	513.1	514.4	512.8	162.1	95.3	139.7	508.0	13.0	74.0
24	914.4	702.0	692.2	69.9	590.6	616.0	616.0	614.4	168.1	106.4	152.4	609.6	13.0	83.0

Notes

- (1) For the 'Bore' (B1) other than Standard Wall Thickness, refer to page 50, 51.
- (2) Class 300 flanges except Lap Joint will be furnished with 0.06" (1.6mm) raised face, which is included in 'Thickness' (t) and 'Length through'.
- (3) For Slip-on, Threaded, Socket Welding and Lap Joint Flanges, the hubs can be shaped either vertical from base to top or tapered within the limits of 7 degrees.

CLASS 300 FLANGES

ASME B16.5

ASME B16.5 FORGED FLANGES

Nominal Pipe Size	Depth of Socket	DRILLING			BOLTING			APPROXIMATE WEIGHT										
		Bolt Circle Diam.	Number of Holes	Diam of Holes	Diam of Bolt (inch)	Machine Bolt Length		Stud Bolt Length	Welding Neck		Slip-on and Threaded		Lap Joint		Blind		Socket Welding	
						Raised Face	Raised Face		Ring Joint	Kg	lb	Kg	lb	Kg	lb	Kg	lb	Kg
Y																		
1/2	9.7	66.7	4	15.8	1/2	55	65	75	0.80	1.70	0.70	1.40	0.61	1.30	0.70	1.40	0.70	1.40
3/4	11.2	82.6	4	19.1	5/8	65	75	90	1.40	3.00	1.30	2.50	1.30	2.50	1.40	2.50	1.34	2.60
1	12.7	88.9	4	19.1	5/8	65	75	90	1.70	3.60	1.50	3.10	1.50	3.00	1.50	3.00	1.55	3.20
1 1/4	14.2	98.6	4	19.1	5/8	70	85	95	2.20	4.50	1.80	3.70	1.70	3.70	2.80	3.90	1.90	3.80
1 1/2	15.7	114.3	4	22.2	3/4	75	90	100	3.20	6.70	2.60	5.60	2.60	5.60	2.90	5.90	2.80	5.80
2	17.5	127.0	8	19.1	5/8	75	90	100	3.60	7.50	3.40	6.20	3.00	6.20	3.32	6.80	3.30	6.50
2 1/2	19.1	149.4	8	22.2	3/4	85	100	115	5.40	11.70	4.50	9.40	4.50	9.30	5.40	10.50	4.74	9.90
3	20.6	168.3	8	22.2	3/4	90	110	120	7.40	16.10	6.10	12.80	5.80	12.70	7.00	14.90	6.30	13.70
3 1/2	22.4	184.2	8	22.2	3/4	95	110	125	8.90	18.00	7.90	17.00	7.72	17.00	9.53	21.00		
4	23.9	200.2	8	22.2	3/4	95	115	125	11.90	24.90	10.13	22.30	10.07	22.20	12.00	26.50		
5	23.9	235.0	8	22.2	3/4	110	120	135	16.00	33.30	13.00	27.70	13.00	27.60	16.00	35.20		
6	26.9	269.7	12	22.2	3/4	110	120	140	20.00	43.40	17.00	35.40	16.00	35.20	22.00	46.70		
8	31.8	330.2	12	25.4	7/8	120	140	150	31.00	67.20	26.00	54.00	25.00	53.70	36.00	76.30		
10	33.3	387.4	16	28.4	1	140	160	170	44.30	96.40	37.10	75.30	39.92	88.00	57.00	122.00		
12	39.6	450.9	16	31.8	1 1/8	145	170	185	64.41	142.00	51.26	113.00	60.00	129.40	82.00	174.00		
14	41.4	514.4	20	31.8	1 1/8	160	180	190	88.30	194.10	75.00	159.00	85.00	184.00	110.00	236.00		
16	44.5	571.5	20	34.9	1 1/4	165	190	205	115.00	249.00	97.00	199.30	112.00	234.00	140.00	307.00		
18	49.3	628.7	24	34.9	1 1/4	170	195	210	143.00	305.00	123.00	240.30	135.00	295.30	178.00	396.00		
20	54.1	685.8	24	34.9	1 1/4	185	205	220	175.00	369.00	136.00	300.00	165.00	347.60	223.17	492.00		
24	63.5	812.8	24	41.1	1 1/2	205	230	255	260.00	519.00	245.00	449.70	250.00	530.00	355.00	754.00		

- (4) Blind Flanges may be made with the same hub as that used for Slip-on Flanges or without hub.
- (5) The gasket surface and backside (bearing surface for bolting) are made parallel within 1 degree. To accomplish parallelism, spot facing is carried out according to MSS AP-9, without reducing thickness (t).
- (6) Depth of Socket (Y) is covered by ANSI B16.5 only in sizes through 3 inch, over 3 inch is at the manufacturer's option.

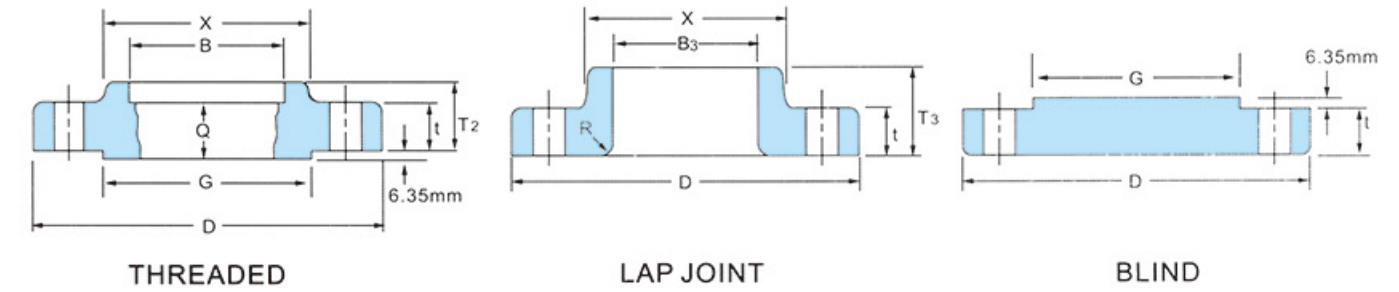
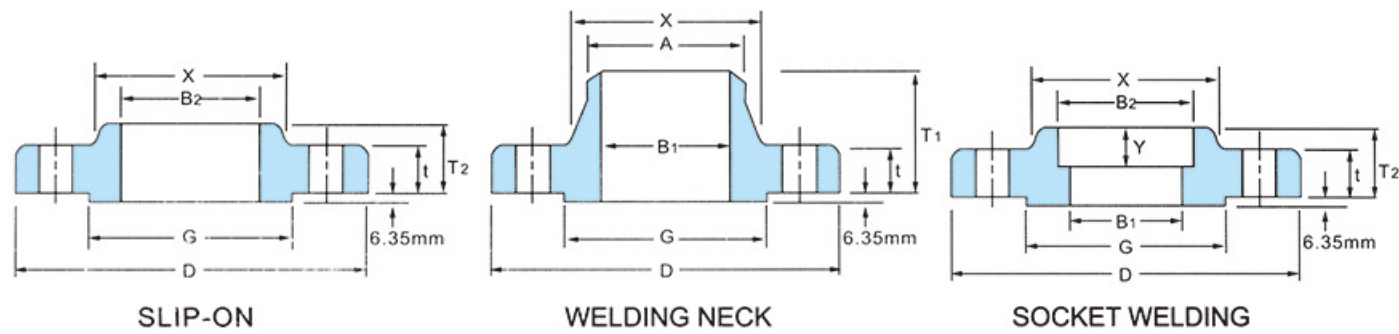

CLASS 600 FLANGES

ASME B16.5

ASME B16.5 FORGED FLANGES

Nominal Pipe Size	Outside Diam.	Diam. at Base of Hub	O.D. of Raised Face	Thickness	BORE				LENGTH THRU HUB					
					Welding Neck Socket Welding	Slip-on Socket Welding	Lap Joint	Counter Bore Min.	Welding Neck	Slip-on Threaded Socket Welding	Lap Joint	Diam. of Hub at Bevel	Radius of Fillet	Thread Length
					B1	B2	B3	B	T1	T2	T3	A	R	Q
1/2	95.3	38.1	35.1	14.2		22.4	22.9	23.6	52.3	22.4	22.4	21.3	3.0	16.0
3/4	117.3	48.0	42.9	15.7		27.7	28.2	29.0	57.2	25.4	25.4	26.7	3.0	16.0
1	124.0	54.0	50.8	17.5		34.5	35.1	35.8	62.0	26.9	26.9	33.5	3.0	18.0
1 1/4	133.4	64.0	63.5	20.6	See Note(1) To be specified by purchaser.	43.2	43.7	44.5	67.0	29.0	29.0	42.2	5.0	21.0
1 1/2	155.4	70.0	73.2	22.4		49.5	50.0	50.5	69.9	32.0	32.0	48.3	6.0	23.0
2	165.1	84.1	91.9	25.4		62.0	62.5	63.5	73.2	37.0	37.0	60.5	8.0	29.0
2 1/2	190.5	100.1	104.6	28.6		74.7	75.4	76.2	79.2	41.1	41.1	73.2	8.0	32.0
3	209.6	117.3	127.0	31.8		90.7	91.4	92.2	83.0	46.0	46.0	88.9	10.0	35.0
3 1/2	228.6	133.4	139.7	35.1		103.4	104.1	104.9	86.0	49.3	49.3	101.6	10.0	40.0
4	273.1	152.4	157.2	38.1		116.1	116.8	117.6	102.0	54.0	54.0	114.3	11.0	42.0
5	330.2	189.0	185.7	44.5		143.8	144.5	144.4	114.3	60.5	60.5	141.2	11.0	48.0
6	355.6	222.3	215.9	47.8		170.7	171.5	171.4	117.3	67.0	67.0	168.4	13.0	51.0
8	419.1	273.1	269.7	55.6		221.5	222.3	222.3	133.4	76.2	76.2	219.2	13.0	58.0
10	508.0	342.9	323.9	63.5		276.4	277.4	276.4	152.4	86.0	111.3	273.1	13.0	66.0
12	558.8	400.1	381.0	66.7		327.2	328.2	328.7	156.0	92.0	117.3	323.9	13.0	70.0
14	603.3	432.0	412.8	69.9	359.2	360.2	360.4	165.1	94.0	127.0	355.6	13.0	74.0	
16	685.8	495.3	469.9	76.2	410.5	411.2	411.2	178.0	106.4	140.0	406.4	13.0	78.0	
18	743.0	546.1	533.4	82.6	461.8	462.3	462.0	184.2	117.3	152.4	457.2	13.0	80.0	
20	812.8	610.0	584.2	88.9	513.1	514.4	512.8	190.5	127.0	165.1	508.0	13.0	83.0	
24	939.8	718.0	692.2	101.6	616.0	616.0	614.4	203.2	140.0	184.2	609.6	13.0	93.0	

Notes

- (1) For the inside diameter of pipes (corresponding to 'Bore' (B1) of Welding Neck Flanges), refer to page 50, 51.
- (2) Class 600 flanges except Lap Joint will be furnished with 0.25" (6.35mm) raised face, which is not included in 'Thickness' (t) and 'Length through Hub' (T1), (T2).
- (3) For Slip-on, Threaded, Socket Welding and Lap Joint Flanges, the hubs can be shaped either vertical from base to top or tapered within the limits of 7 degrees.

CLASS 600 FLANGES

ASME B16.5

ASME B16.5 FORGED FLANGES

Nominal Pipe Size	Depth of Socket	DRILLING			BOLTING			APPROXIMATE WEIGHT										
		Bolt Circle Diam.	Number of Holes	Diam of Holes	Diam of Bolt (inch)	Stud Bolt Length			Welding Neck		Slip-on and Threaded		Lap Joint		Blind		Socket Welding	
						0.25" Raised Face	Male-Female Tongue-Groove	Ring Joint	Kg	lb	Kg	lb	Kg	lb	Kg	lb	Kg	lb
1/2	9.7	66.7	4	15.8	1/2	75	70	75	0.98	2.00	0.98	2.00	0.98	1.80	0.98	2.00	0.98	2.00
3/4	11.2	82.6	4	19.1	5/8	90	85	90	1.60	3.50	1.60	3.00	1.40	3.00	1.40	3.00	1.40	3.00
1	12.7	88.9	4	19.1	5/8	90	85	90	2.00	4.00	2.00	3.70	2.00	3.50	2.00	4.00	2.11	4.00
1 1/4	14.2	98.6	4	19.1	5/8	95	90	95	2.80	5.50	2.70	5.00	2.70	4.50	2.70	5.30	3.03	5.70
1 1/2	15.7	114.3	4	22.2	3/4	110	100	110	3.80	8.00	3.80	6.80	3.80	6.50	3.80	7.50	3.88	7.00
2	17.5	127.5	8	19.1	3/4	110	100	110	4.70	10.00	4.10	8.00	4.00	8.00	4.60	9.70	4.37	8.60
2 1/2	19.1	149.4	8	22.2	3/4	120	115	120	8.20	14.00	5.90	12.00	5.90	11.00	6.80	15.00	6.36	13.00
3	20.6	168.1	8	22.2	3/4	125	120	125	8.80	18.00	7.30	16.00	7.30	14.00	8.90	19.60	7.59	16.30
3 1/2	22.4	184.2	8	25.4	7/8	140	135	140	12.00	26.00	9.53	21.00	9.40	20.00	13.17	29.00		
4	23.9	215.9	8	25.4	7/8	145	140	145	18.10	37.00	17.00	33.00	17.00	31.00	18.60	41.00		
5	23.9	266.7	8	28.4	1	165	160	165	31.00	68.00	29.00	62.80	29.00	60.60	30.84	68.00		
6	26.9	292.1	12	28.4	1	170	165	170	36.77	80.00	36.32	80.00	36.00	78.00	39.00	83.80		
8	31.8	349.3	12	31.8	1 1/8	190	185	190	55.00	112.00	52.00	97.00	52.00	112.00	64.00	137.00		
10	33.3	431.8	16	35.1	1 1/4	215	210	215	90.70	190.00	77.00	168.00	77.00	163.00	102.00	224.90		
12	39.6	489.0	20	35.1	1 1/4	220	215	220	110.00	226.00	97.52	215.00	108.86	240.00	132.00	291.00		
14	41.4	527.1	20	38.1	1 3/8	235	230	235	150.00	268.00	102.00	224.80	113.00	244.70	159.00	348.30		
16	44.5	603.3	20	41.1	1 1/2	255	250	255	190.00	290.00	149.82	330.20	165.71	365.30	224.73	495.40		
18	49.3	654.1	20	44.5	1 5/8	275	265	275	240.00	475.40	182.00	412.30	197.00	427.70	285.00	628.30		
20	54.1	723.9	24	44.5	1 5/8	285	280	290	295.00	590.50	231.54	510.50	260.00	570.50	365.00	804.70		
24	63.5	838.2	24	50.8	1 7/8	330	325	330	408.00	820.00	330.00	725.50	370.00	798.00	565.00	1176.0		

- (4) Blind Flanges may be made with the same hub as that used for Slip-on Flanges or without hub.
- (5) The gasket surface and backside (bearing surface for bolting) are made parallel within 1 degree. To accomplish parallelism, spot facing is carried out according to MSS SP-9, without reducing thickness (t).
- (6) Dimensions of size 1/2" through 3 1/2" are the same as for Class 400 Flanges.
- (7) Depth of Socket (Y) is covered by ANSI B16.5 only in sizes through 3 inch, over 3 inch is at the manufacturer's option.

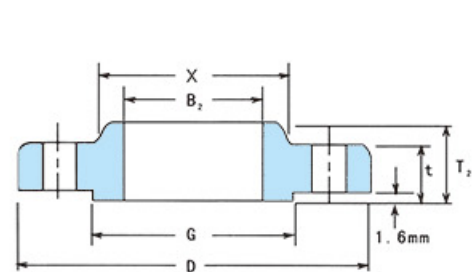

SLIP-ON

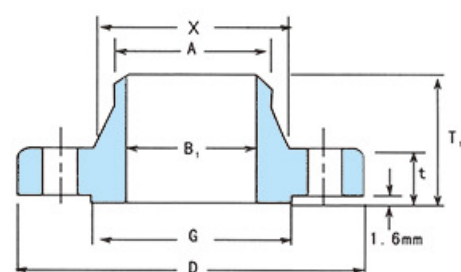

WELDING NECK

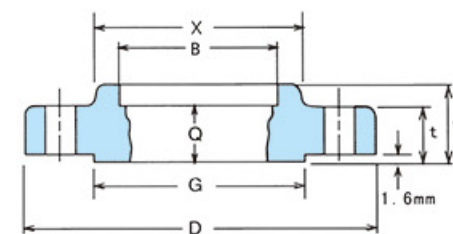

THREADED

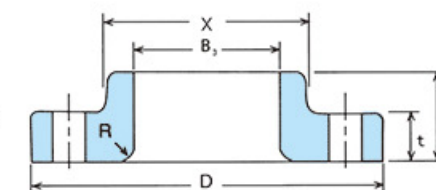

LAP JOINT

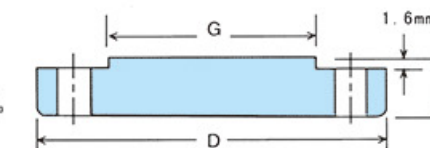

BLIND

CLASS 900 FLANGES

ASME B16.5

ASME B16.5 FORGED FLANGES

Nominal Pipe Size	Outside Diam. D	Diam. at Base of Hub x	O.D. of Raised Face G	Thickness t	BORE				LENGTH THRU HUB			
					Welding Neck B1	Slip-on B2	Lap Joint B3	Counter Bore Min. Threaded B	Welding Neck T1	Slip-on Threaded T2	Lap Joint T3	Diam. of Hub at Bevel A
1/2	120.7	38.1	35.1	22.4		22.4	22.9	23.6	60.5	31.8	31.8	21.3
3/4	130.0	44.5	42.9	25.4		27.7	28.2	29.0	69.9	35.1	35.1	26.7
1	149.4	52.3	50.8	28.6		34.5	35.1	35.8	73.2	41.1	41.1	33.5
1 1/4	158.8	64.0	63.5	28.6		43.2	43.7	44.5	73.2	41.1	41.1	42.2
1 1/2	177.8	70.0	73.2	31.8		49.5	50.0	50.3	82.6	44.5	44.5	48.3
2	215.9	105.0	91.9	38.1		62.0	62.0	63.5	102.0	57.2	57.2	60.5
2 1/2	244.3	124.0	104.6	41.3		74.7	75.4	76.2	105.0	64.0	64.0	73.2
3	241.3	127.0	127.0	38.1		90.7	91.4	92.2	102.0	54.0	54.0	88.9
4	292.1	158.8	157.2	44.5		116.1	116.8	117.6	114.3	70.0	70.0	114.3
5	349.3	190.5	185.7	50.8		143.8	144.5	144.5	127.0	79.2	79.2	141.2
6	381.0	235.0	215.9	55.6		170.7	171.5	171.5	140.0	86.0	86.0	168.4
8	369.9	298.5	269.7	63.5		221.5	222.3	222.3	162.1	102.0	114.3	219.2
10	546.1	368.0	323.9	69.9		276.4	277.4	276.4	184.2	108.0	127.0	273.1
12	609.6	419.1	381.0	79.4		327.2	328.2	328.7	200.2	117.3	143.0	323.9
14	641.4	450.9	412.8	85.9		359.2	360.2	360.2	213.0	130.3	156.0	355.6
16	704.9	508.0	469.9	88.9		410.5	411.2	411.2	215.9	133.4	165.1	406.4
18	787.4	565.2	533.4	101.6		461.8	462.3	462.0	228.6	152.4	190.5	457.2
20	857.3	622.3	584.2	108.0		513.1	514.4	514.8	248.0	159.0	210.0	508.0
24	1041.4	749.3	692.2	139.7		616.0	616.0	614.4	292.1	203.2	267.0	609.6

Notes

(1) Class 900 flanges except Lap Joint will be furnished with 0.25"(6.35mm) raised face, which is not included in 'Thickness' (t) and 'Length through Hub' (T1),(T2).

(2) For Slip-on, Threaded, Socket Welding and Lap Joint Flanges, the hubs can be shaped either vertical from base to top or tapered within the limits of 7 degrees.

CLASS 900 FLANGES

ASME B16.5

ASME B16.5 FORGED FLANGES

Nominal Pipe	Radius of Fillet R	Thread Length Q	DRILLING			BOLTING				APPROXIMATE WEIGHT							
			Bolt Circle Diam.	Number of Holes	Diam. Of Holes	Stud Bolt Length			Welding Neck		Slip-on and Threaded		Lap Joint		Blind		
						Diam. Of Bolts (inch)	0.25-Raised Face	Male-Female Tongue-Groove	Ring Joint	Kg	lb	Kg	lb	Kg	lb	Kg	lb
1/2	3.0	23	82.6	4	22.2	3/4	110	100	110	3.18	4.60	1.75	4.00	1.8	4.00	1.78	4.20
3/4	3.0	26	88.9	4	22.2	3/4	115	110	115	3.18	6.00	2.35	5.30	2.35	5.00	2.43	6.00
1	3.0	29	101.6	4	25.4	7/8	125	120	125	3.86	8.50	3.5	7.50	3.6	7.50	3.65	9.00
1 1/4	5.0	31	111.3	4	25.4	7/8	125	120	125	4.54	10.00	4.01	9.00	4.1	9.00	4.27	10.00
1 1/2	6.0	32	124.0	4	28.4	1	140	130	140	6.36	13.00	5.52	12.00	5.4	11.90	5.93	13.00
2	8.0	39	165.1	8	25.4	7/8	145	140	145	10.9	24.00	9.81	22.00	11.4	21.00	10	25.00
2 1/2	8.0	48	190.5	8	28.4	1	160	150	160	16.3	36.00	13.5	34.80	15.9	29.00	14	35.30
3	10.0	42	190.5	8	25.4	7/8	145	140	145	13.2	33.00	11.5	26.00	11.4	25.00	15.1	29.00
4	11.0	48	235.0	8	31.8	1 1/8	170	165	170	23.2	51.00	19.4	51.00	23.2	48.50	21.8	54.00
5	11.0	54	279.4	8	35.1	1 1/4	190	185	190	39.1	84.90	32.4	83.00	36.8	81.00	34.8	87.00
6	13.0	58	317.5	12	31.8	1 1/8	190	185	190	49.9	110.00	41	106.50	47.7	104.70	47.5	113.50
8	13.0	64	393.7	12	38.1	1 3/8	220	215	220	84.9	175.00	70.6	166.30	86.3	189.60	82.4	186.20
10	13.0	72	469.9	16	38.1	1 3/8	235	230	235	121.7	260.00	99.7	245.00	124.9	277.00	122.2	290.00
12	13.0	77	533.4	20	38.1	1 3/8	255	250	255	168.9	346.00	132.3	321.80	168	368.00	173.7	412.30
14	13.0	83	558.8	20	41.1	1 1/2	275	265	280	255.2	400.40	151.8	380.00	188.4	397.00	205.7	494.00
16	13.0	86	616.0	20	44.5	1 5/8	285	280	290	311	495.50	184.1	425.40	211.1	465.40	259.9	600.50
18	13.0	89	685.8	20	50.8	1 7/8	325	320	335	419.5	680.60	256.1	600.50	295.1	650.60	366.9	850.80
20	13.0	93	749.3	20	53.8	2	350	345	360	528.5	830.70	333.2	730.60	367.7	810.70	461	1076.00
24	13.0	102	901.7	20	66.5	2 1/2	440	430	455	956.6	1510.00	600	1393.30	703.7	1543.00	874	1995.00

(3) Blind Flanges may be made with the same hub as that used for Slip-on Flanges or without hub.

(4) The gasket surface and backside (bearing surface for bolting) are made parallel within 1 degree. To accomplish parallelism, spot facing is carried out according to MSS AP-9, without reducing thickness (t).

(5) Dimensions of sizes 1/2" through 2 1/2" are the same as for Class 1500 Flanges.

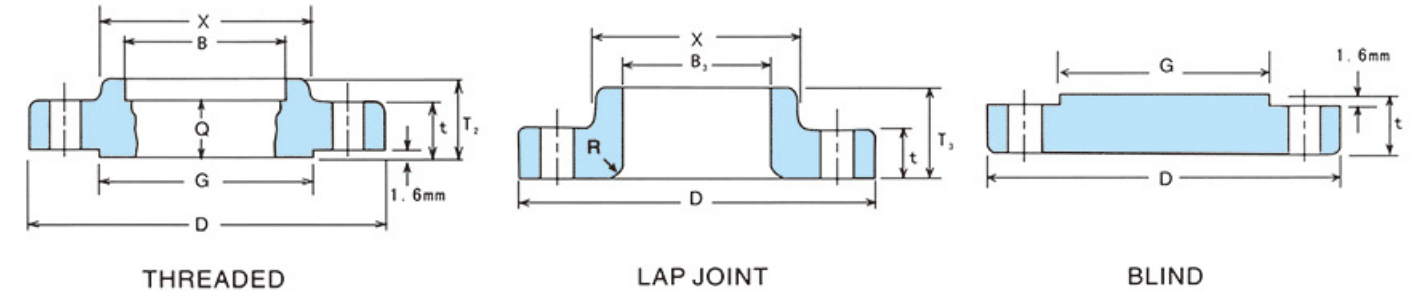
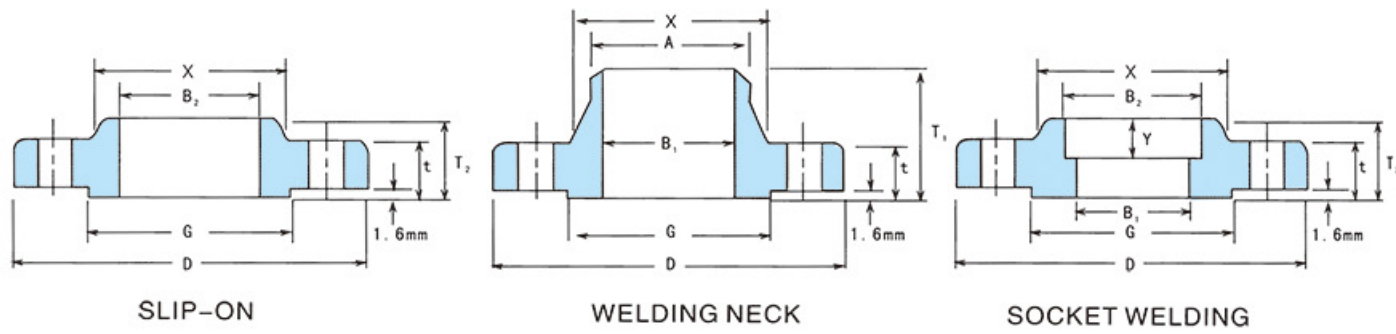

CLASS 1500 FLANGES ASME B16.5

ASME B16.5 FORGED FLANGES

Nominal Pipe Size	Outside Diam D	Diam. at Base of Hub x	O.D. of Raised Face G	Thickness t	BORE				LENGTH THRU HUB			Diam. of Hub at Bevel A	Radius of Fillet R	Thread Length Q
					Welding Neck Socket Welding B1	Slip-on Socket Welding B2	Lap Joint B3	Counter Bore Min. B	Welding Neck T1	Slip-on Threaded Socket Welding T2	Lap Joint T3			
1/2	120.7	38.1	35.1	22.4		22.4	22.9	23.6	60.5	31.8	31.8	21.3	3.0	23.0
3/4	130.0	44.5	42.9	25.4		27.7	28.2	29.0	69.9	35.1	35.1	26.7	3.0	26.0
1	149.4	52.3	50.8	28.6		34.5	35.1	35.8	73.2	41.1	41.1	33.5	3.0	29.0
1 1/4	158.8	64.0	63.5	28.6		43.2	43.7	44.5	73.2	41.1	41.1	42.2	5.0	31.0
1 1/2	177.8	70.0	73.2	31.8		49.5	50.0	50.0	82.6	44.5	44.5	48.3	6.0	32.0
2	215.9	105.0	91.9	38.1		62.0	62.5	63.5	102.0	57.2	57.2	60.5	8.0	39.0
2 1/2	244.3	124.0	104.6	41.3		74.7	75.4	76.2	105.0	64.0	64.0	73.2	9.7	48.0
3	266.7	133.4	127.0	47.8		90.7	91.4	92.2	117.3	-	73.2	88.9	10.0	-
4	311.2	162.1	157.2	54.0		116.1	116.8	117.6	124.0	-	90.4	114.3	11.0	-
5	374.7	197.0	185.7	73.2		143.8	144.5	144.5	156.0	-	104.6	141.2	11.0	-
6	393.7	229.0	215.9	82.6		170.7	171.5	171.5	171.5	-	119.1	168.4	13.0	-
8	482.6	292.1	269.7	92.0		221.5	222.3	222.3	213.0	-	143.0	219.2	13.0	-
10	584.2	368.3	323.9	108.0		276.4	277.4	276.4	254.0	-	178.0	273.1	13.0	-
12	673.1	451.0	381.0	124.0		327.2	328.2	328.7	283.0	-	219.0	323.9	13.0	-
14	749.3	495.3	412.8	133.4		359.2	360.2	360.4	298.5	-	241.3	355.6	13.0	-
16	825.5	552.5	469.9	146.1		410.5	411.2	411.2	311.2	-	260.4	406.4	13.0	-
18	914.4	597.0	533.4	162.1		461.8	462.3	462.0	327.2	-	276.4	457.2	13.0	-
20	984.3	641.4	584.2	177.8		513.1	514.4	512.8	356.0	-	292.1	508.0	13.0	-
24	1168.4	762.0	692.2	203.2		616.0	616.0	614.4	406.4	-	330.2	609.6	13.0	-

Notes

(1) Class 1500 flanges except Lap Joint will be furnished with 0.25"(6.35mm) raised face, which is not included in 'Thickness' (t) and 'Length through Hub' (T1),(T2).

(2) For Slip-on, Threaded, Socket Welding and Lap Joint Flanges, the hubs can be shaped either vertical from base to top or tapered within the limits of 7 degrees.

CLASS 1500 FLANGES ASME B16.5

ASME B16.5 FORGED FLANGES

Nominal Pipe Size	Depth of Socket Y	DRILLING			BOLTING			APPROXIMATE WEIGHT										
		Bolt Circle Diam.	Number of Holes	Diam. Of Holes	Diam of Bolt (inch)	Stud Bolt Length			Welding Neck		Slip-on and Threaded		Lap Joint		Blind		Socket Welding	
						0.25-Raised Face	Male-Female Tongue Groove	Ring Joint	Kg	lb	Kg	lb	Kg	lb	Kg	lb	Kg	lb
1/2	9.7	82.6	4	22.2	3/4	110	100	110	3.18	4.60	1.75	4.00	1.8	4.00	1.78	4.00	1.75	4.00
3/4	11.2	88.9	4	22.2	3/4	115	110	115	3.18	6.00	2.35	5.00	2.35	5.00	2.43	6.00	2.35	6.20
1	12.7	101.6	4	25.4	7/8	125	120	125	3.86	8.50	3.5	7.50	3.6	7.50	3.65	9.00	3.5	8.00
1 1/4	14.2	111.3	4	25.4	7/8	125	120	125	4.54	10.00	4.01	9.00	4.1	10.80	4.27	9.50	4.01	11.00
1 1/2	15.7	124.0	4	28.5	1	140	135	140	6.36	13.00	5.52	12.00	5.52	11.90	5.93	13.00	5.52	14.90
2	17.5	165.1	8	25.4	7/8	145	140	145	10.9	24.00	9.81	23.00	11.4	21.00	10	25.00	9.81	24.00
2 1/2	19.1	190.5	8	28.4	1	160	150	160	16.34	36.00	13.5	34.80	15.9	29.00	14	35.00	13.5	36.00
3	20.6	203.2	8	31.8	1 1/8	180	170	180	21.8	48.00	21.8	48.00	21.3	38.00	19	48.00		
4	23.9	241.3	8	35.1	1 1/4	195	190	195	31.3	69.00	33.1	68.40	34.1	63.90	29.7	73.00		
5	23.9	292.1	8	41.1	1 1/2	250	240	250	59.9	130.00	59	129.60	63.6	119.00	58.8	132.30		
6	26.9	317.5	12	38.1	1 3/8	260	255	265	74.5	165.00	74.9	163.00	77.2	136.70	72.5	165.30		
8	31.8	393.7	12	44.5	1 5/8	290	285	325	123.9	273.00	118	258.00	129.4	236.00	122.7	302.00		
10	33.3	482.6	12	50.8	1 7/8	335	330	345	206.1	454.00	197.5	435.40	220.4	485.40	211.5	507.00		
12	39.6	571.5	16	53.8	2	375	370	380	313.3	674.00	263.3	582.00	286	630.60	317.4	696.70		
14	41.4	635.0	16	60.5	2 1/4	405	400	425	406.5	917.00	-	-	404.1	890.80	422.7	928.00		
16	44.5	704.9	16	66.5	2 1/2	445	440	470	525	1250.00	-	-	522	1151.00	557.2	1232.70		
18	49.3	774.7	16	73.2	2 3/4	495	490	525	687.2	1622.60	-	-	670	1476.30	760.6	1677.70		
20	54.1	831.9	16	79.2	3	540	535	565	852.6	2048.00	-	-	806	1776.60	966.6	2131.80		
24	63.5	990.6	16	91.9	3 1/2	615	610	650	1366.8	3315.70	-	-	1283	2834.00	1560	3456.80		

(3) Blind Flanges may be made with the same hub as that used for Slip-on Flanges or without hub.

(4) The gasket surface and backside (bearing surface for bolting) are made parallel within 1 degree. To accomplish parallelism, spot facing is carried out according to MSS SP-9, without reducing thickness (t).

(5) Dimensions of sizes 1/2" through 2 1/2" are the same as for Class 900 Flanges.

(6) Depth of Socket (Y) is covered by ANSI B16.5 only in sizes through 2 1/2"-inch, over 2 1/2"-inch is at the manufacturer's option.

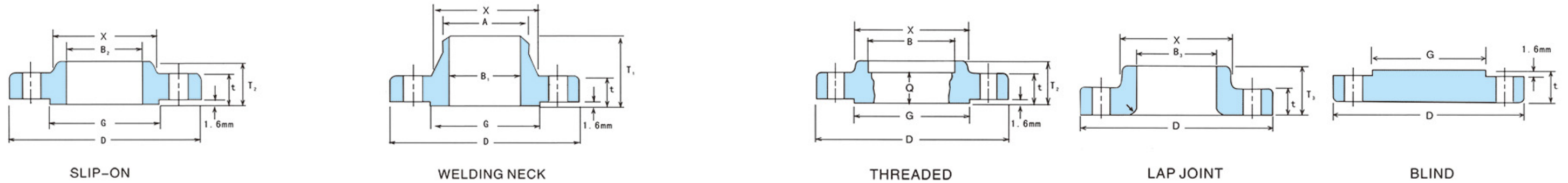

CLASS 2500 FLANGES ASME B16.5

ASME B16.5 FORGED FLANGES

Nominal Pipe Size	Outside Diam	Diam. at Base of Hub	O.D. of Raised Face	Thickness	BORE				LENGTH THRU HUB			Diam. of Hub at Bevel	Radius of Fillet	Thread Length
					Welding Neck Socket Welding	Slip-on Socket Welding	Lap Joint	Counter Bore Min.	Welding Neck	Slip-on Threaded Socket Welding	Lap Joint			
1/2	133.4	43.0	35.1	30.2	To be specified by purchaser	22.4	22.9	23.6	73.2	39.6	40.0	21.3	3.0	29.0
3/4	139.7	51.0	42.9	31.8		27.7	28.2	29.0	79.2	42.9	43.0	26.7	3.0	32.0
1	158.8	57.2	50.8	35.1		34.5	35.1	35.8	89.0	47.8	47.8	33.5	3.0	35.0
1 1/4	184.2	73.2	63.5	38.1		43.2	43.7	44.4	95.3	52.3	52.3	42.2	5.0	39.0
1 1/2	203.2	79.2	73.2	44.5		49.5	50.0	50.3	111.3	60.5	60.5	48.3	6.0	45.0
2	235.0	95.3	91.9	50.8		62.0	62.5	63.5	127.0	69.9	70.0	60.5	8.0	51.0
2 1/2	266.7	114.3	104.6	57.2		74.7	75.4	76.2	142.7	79.2	79.0	73.2	8.0	58.0
3	304.8	133.4	127.0	66.7		90.7	91.4	92.2	168.1	91.9	92.0	88.9	10.0	-
4	355.6	165.1	157.2	76.2		116.1	116.8	117.6	190.5	108.0	108.0	114.3	11.0	-
5	419.1	203.2	185.7	92.0		143.8	144.5	144.4	228.6	130.0	130.0	141.2	11.0	-
6	482.6	235.0	215.9	108.0		170.7	171.5	171.5	273.1	152.4	152.4	168.4	13.0	-
8	552.5	305.0	269.7	127.0		221.5	222.3	222.3	317.5	177.8	178.0	219.2	13.0	-
10	673.1	375.0	323.9	165.1		276.4	277.4	276.4	419.1	228.6	229.0	273.1	13.0	-
12	762.0	441.5	381.0	184.2		327.2	328.2	328.6	463.6	254.0	254.0	323.9	13.0	-

Notes

(1) Class 2500 flanges except Lap Joint will be furnished with 0.25"(6.35mm) raised face, which is not included in 'Thickness' (t) and 'Length through Hub' (T₁), (T₂).

(2) For Slip-on, Threaded, Socket Welding and Lap Joint Flanges, the hubs can be shaped either vertical from base to top or tapered within the limits of 7 degrees.

CLASS 2500 FLANGES ASME B16.5

ASME B16.5 FORGED FLANGES

Nominal Pipe Size	DRILLING			BOLTING				APPROXIMATE WEIGHT							
	Bolt Circle Diam.	Number of Holes	Diam. Of Holes	Stud Bolt Length				Welding Neck		Slip-on and Threaded		Lap Joint		Blind	
				Diam of Bolt (inch)	0.25-Raised Face	Male-Female Tongue Groove	Ring Joint	Kg	lb	Kg	lb	Kg	lb	Kg	lb
1/2	88.9	4	22.2	3/4	120	115	120	3.63	7.00	3.20	7.00	3.00	6.60	3.11	7.00
3/4	95.3	4	22.2	3/4	125	120	125	4.09	9.00	4.08	9.00	3.63	8.00	3.56	10.00
1	108.0	4	25.4	7/8	140	135	140	5.9	12.00	5.44	12.00	4.99	11.00	5.05	12.00
1 1/4	130.0	4	28.4	1	150	145	150	9.08	20.00	8.16	18.00	7.26	16.00	7.47	18.00
1 1/2	146.1	4	31.8	1 1/8	170	165	170	12.7	25.00	11.00	24.30	9.99	22.00	10.6	23.00
2	171.5	8	28.4	1	180	170	180	19.1	42.00	17.25	38.00	16.80	37.00	15.5	39.00
2 1/2	196.9	8	31.8	1 1/8	195	190	205	23.6	52.00	24.97	55.00	24.06	53.00	22.4	56.00
3	228.6	8	35.1	1	220	215	230	42.7	94.00	37.68	83.00	36.32	80.00	34.9	86.00
4	273.1	8	41.1	1 1/8	255	250	260	66.3	141.00	58.00	127.90	54.48	120.00	53.8	133.00
5	323.9	8	47.8	1 1/4	300	290	310	110.8	244.00	95.30	210.00	92.53	204.00	91.5	223.00
6	368.3	8	53.8	1 1/2	345	335	355	171.6	378.00	147.40	323.00	143.01	315.30	142.5	345.30
8	438.2	12	53.8	1 3/4	380	375	395	261.5	576.00	220.00	485.00	213.38	470.40	211.5	530.50
10	539.8	12	66.5	2	490	485	510	484.9	1068.00	421.80	925.00	408.60	900.80	412.6	1026.00
12	619.3	12	73.2	2	540	535	560	730.1	1526.30	590.20	1301.00	572.95	1263.00	588.2	1464.00

(3) Blind Flanges may be made with the same hub as that used for Slip-on Flanges or without hub.

(4) The gasket surface and backside (bearing surface for bolting) are made parallel within 1 degree. To accomplish parallelism, spot facing is carried out according to MSS AP-9, without reducing thickness (t).

(5) Class 2500 Slip-on Flanges are not covered by ANSI B16.5 Slip-on flanges are at the manufacture's option.